

户内 单相 环氧树脂浇注式
INDOOR SINGLE-PHASE EPOXY RESIN CASTING TYPE

技术参数 Technical data

- 产品性能符合标准 GB1207和IEC60044-2
The voltage transformers are in accordance with GB1207 and IEC60044-2 standards
- 额定绝缘水平 12/42/75、7.2/32/60kV
Rated insulation level 12/42/75、7.2/32/60kV
- 额定频率50Hz或60Hz
Rated frequency 50Hz or 60Hz



型号 Type	额定电压比 Rated voltage ratio (V)	额定二次输出 Rated secondary output(VA)						极限输出 Max.output (VA)	额定绝缘水平 Rated insula- tion level(kV)	接线图 Wiring diagram
		0.2	0.5	1级	3级	0.2/0.2 0.2/0.5	0.5/0.5			
JDZ12A-3	3000/100	30	90	250	400	/	/	1000	3.6/23/40	图1-图2 Figure1-2
JDZ12A-6	6000/100								7.2/32/60	
JDZ12A-10	10000/100									
JDZ16-6	10000/220									
JDZ12A-10	10000/100/100	/	/	/	/	20/20	50/50	500/500	12/42/75	图3-图4 Figure3-4
JDZ16-10	10000/100/200	/	/	/	/	20/30				
						0.2/3--30/400 0.5/3--90/400		800/1000		
JDZ12A-3R	3000/100	30	90	250	400	/	/	1000	3.6/23/40	图1-图2 Figure1-2
JDZ12A-6R	6000/100								7.2/32/60	
JDZ12A-10R	10000/100									
JDZ16-6R	10000/200									
JDZ12A-10R	10000/100/100	/	/	/	/	20/20	50/50	500/500	12/42/75	图3-图4 Figure3-4
JDZ16-10R	10000/100/220	/	/	/	/	20/30				
						0.2/3--30/400 0.5/3--90/400		800/1000		

注：一次端子电缆接连形式：

JDZ12A-3.6.10一次端子与美式200A肘型插头配套使用。

JDZ12A-3.6.10R一次端子与美式200A大口肘型插头配套使用。

Note: The first wiring point connection mode:

JDZ12A-3.6.10First wiring point and 200A Amemcan Type elbow ping cooperate.

JDZ12A-3.6.10R Fist wiring pomt and 200A Amemcan Type heavy cabre elbow piug cooperate.

外形及安装尺寸 Overall dimension drawing

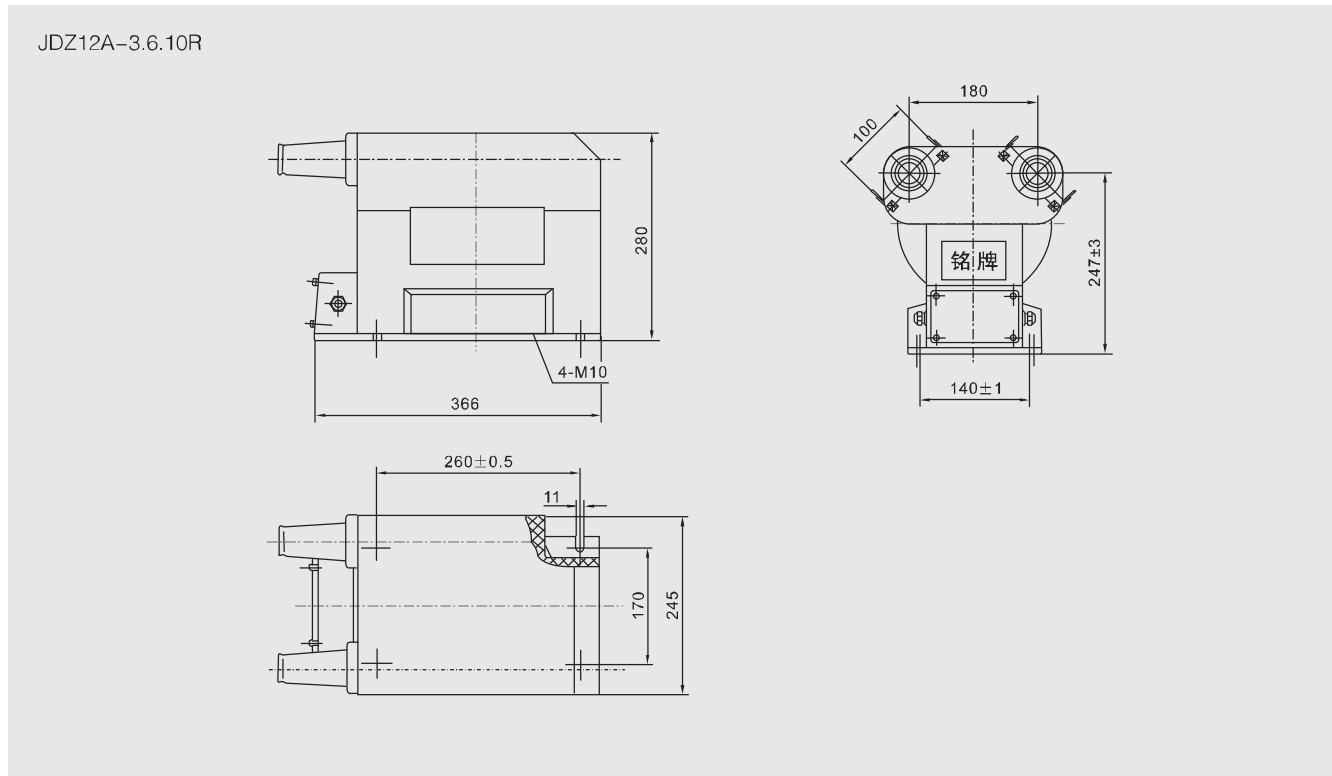

接线图 Wiring diagram

